



ROTARY TRANSDUCERS



Rotary transducers are designed to measure the torque from continuously rotating shafts such as impulse power tools and certain non-impulse tools with a severe clutch action.

This range offers class-leading performance with impulse tools and will be supplied with a UKAS accredited calibration certificate from Norbar's laboratory.

These transducers are known as Smart transducers. They have built-in intelligence in the form of a memory circuit which contains essential information about the transducer which can be read by the appropriate type of instrument (TST, TTT, TTL-HE & T-Box XL™), thus reducing set-up time.

They will also work with instruments that cannot read the memory information, by inputting the relevant calibration details manually.

Note: Not for use with Impact Tools.

Angle measurement also available.



4	ROTARY TRANSDUCERS
50708.xxx	0.25 - 5 N·m ¼" M/F Hex
50709.xxx	1 - 20 N·m ¼" M/F Hex
50710.xxx	1 - 20 N·m ¼" M/F sq. dr.
50719.xxx	0.75 - 15 lbf-ft ¼" M/F sq. dr.
50711.xxx	3.75 - 75 N·m ⅜" M/F sq. dr.
50720.xxx	2.5 - 50 lbf-ft ⅜" M/F sq. dr.
50712.xxx	10 - 200 N·m ½" M/F sq. dr.
50721.xxx	7.5 - 150 lbf-ft ½" M/F sq. dr.

4	ROTARY TRANSDUCERS
50713.xxx	12.5 - 250 N·m ¾" M/F sq. dr.
50722.xxx	10 - 200 lbf-ft ¾" M/F sq. dr.
50714.xxx	25 - 500 N·m ¾" M/F sq. dr.
50723.xxx	15 - 300 lbf-ft ¾" M/F sq. dr.
50715.xxx	75 - 1,500 N·m 1" M/F sq. dr.
50724.xxx	50 - 1,000 lbf-ft 1" M/F sq. dr.
TD2.CCW	Counter-clockwise calibration.

Angle options available, contact Norbar.

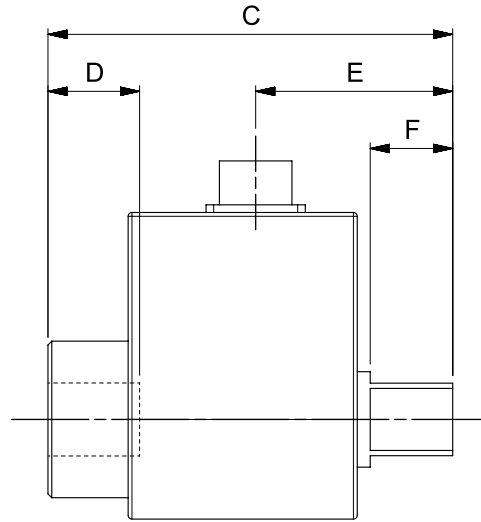
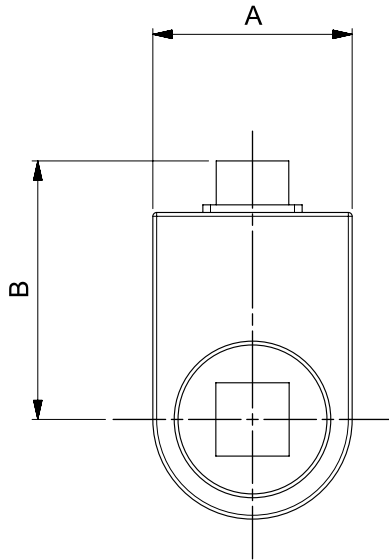

Model	¼" M/F Hex	¼" M/F SQ DR	⅜" M/F SQ DR	½" M/F SQ DR	¾" M/F SQ DR	1" M/F SQ DR	
Part Number	50708.xxx 50709.xxx	50710.xxx 50719.xxx	50711.xxx 50720.xxx	50712.xxx 50721.xxx	50713.xxx 50714.xxx 50722.xxx 50723.xxx	50715.xxx 50724.xxx	
Dimensions (mm)	A	30	30	30	42	52	63
	B	58	58	62	67	73	79
	C	116	72	77	87	106	125
	D	N/A	10	13	16	24	29
	E	49	33	36	42	51	61
	F	26	7	11	15	21	26
Weight (kg)	0.2	0.2	0.2	0.4	0.8	1.5	